

ScienceCube



Wireless Gas Pressure (WL103P) User Guide



Rev. WL103P-02-2024

This product is to be used for educational purposes only. It is not appropriate for industrial, medical, research, or commercial applications.

 **KOREADIGITAL**

The Science Cube wireless gas pressure sensors can measure relative atmospheric pressure over a wide range.

The wireless gas pressure sensors measure pressure relative to the surrounding air pressure. The barbed fitting on the front of the sensor allows you to connect experimental devices for various pressure measurements and measure increases or decreases in pressure.

It can measure a wide range from -1 to +3 atm, making it applicable to a variety of experiments. By applying a *Luer* lock type connector, it can be easily connected to the experimental device through a syringe or connector, and the twist-and-joint structure allows for solid fixation even under high pressure.

You can measure by remotely connecting to a smart device or PC wirelessly or wired.

Note : For finer pressure measurements, use Gas Pressure B (WL116P). Pressure within a narrow range can be measured more precisely than Gas Pressure (WL103P).

Suggested experiments

- Boyle's Law
- Cloud creation principle
- Reaction rate according to acid concentration
- Solubility of Gas with Temperature

Composition

The ScienceCube wireless gas pressure sensor consists of the following.

- Wireless Gas Pressure Sensor(WL103P)
- Silicon tube, Plastic syringe 20ml, Plastic barbed fitting

- USB-A/C cable
- Booklet

Feature

- Up to four Science Cube wireless sensors can be connected to a PC or smart device at the same time.
- It supports dual-mode Bluetooth, allowing you to connect not only smart devices but also desktop and laptop PCs to conduct experiments using the **Science#** application.
- It can be connected to a PC through a USB port and experiments can be performed using the **Science#** program.



Function of wireless sensor

Structure

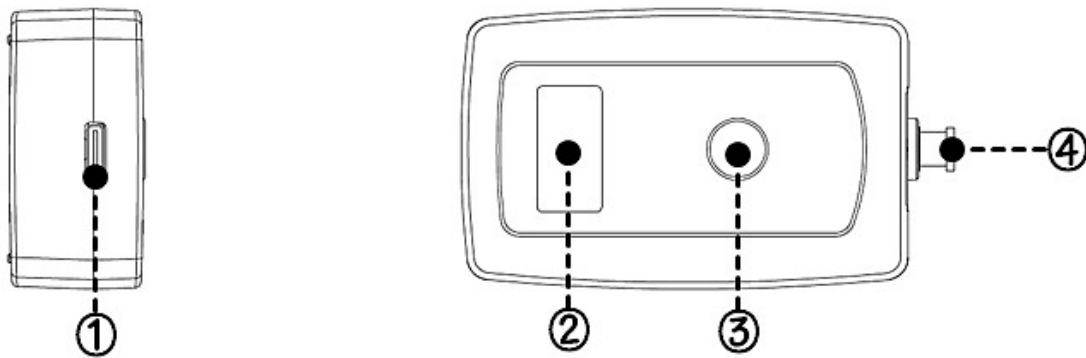

- ① USB port : Connect the sensor to a PC and use it for experiments or charging.
- ② OLED Display : Displays measured sensor values, sensor type, sensor ID, and remaining battery level.
- ③ Power/Function Button : It has functions such as power ON/OFF, measurement sensor change and calibration, etc.
- ④ Sensing part : There is a sensor inside that detects pressure, and it can be connected to a *Luer lock* connector.

Caution : Do not measure beyond the sensor's measurement range. Doing so can reduce the accuracy of the sensor, cause sensor malfunctions, or result in permanent damage. Please use within the safe measurement range.

Power/Function Button

Status	Turn	Action	Description
When the power is off	Click once	■	A short press turns the sensor on.
	Long click	■■■■■	A long press changes the mode and turns on the sensor.
When it's on	Double click	■■	1) Zero point setting (For sensors with zero point function)
	Long click	■■■■■	Turns off.

Start screen

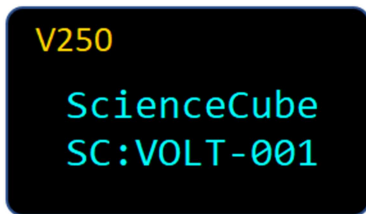

V250 : Displays the sensor's firmware version.

SC:NAME-001 : When you search for a Bluetooth device, the device name will be displayed. (Sensor name and 3-digit serial number)

Mode change

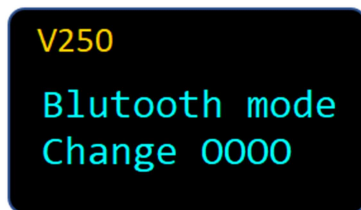

When you press and hold the power button and turn it on, the Bluetooth connection mode changes to **Mobile** or **PC** with the following message.

Measurement screen

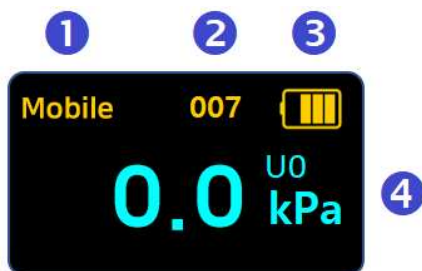

① Connection mode	'Mobile' : Connecting an Android or iOS. 'PC' : Connecting a Windows-based PC.  : Connected via USB cable.
② Sensor-ID	When connecting wirelessly using the sensor's serial number, this is the sensor name displayed in 'Device Name'.
③ Battery	You can check the battery status, and when you connect the USB charging cable, the display changes to charging.
④ Sensor Value	1) Displays sensor measurement values and units in real time. 2) When using 'Zero Point Setting', U0 is displayed above the unit.

How it Works

The Science Cube wireless pressure sensor uses a device with a built-in piezoelectric resistance strain gauge that is deformed by pressure and changes its resistance value.

This strain gauge is arranged in the form of a Wheatstone bridge, so constant power is applied to the top and bottom, so the change in resistance value according to pressure can be read as voltage. The micro-voltage detected in this way is calculated as a pressure value through a signal amplifier and digital converter.

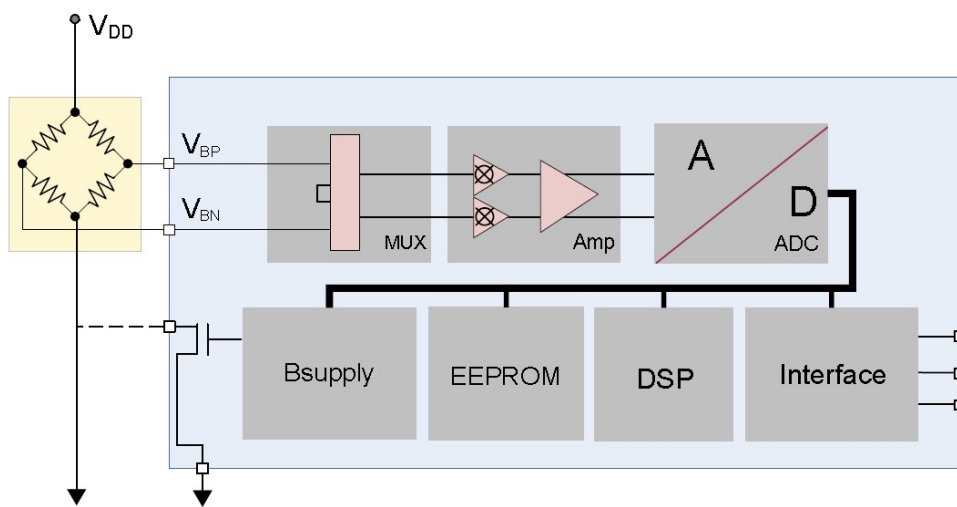

Using the Sensor

The ScienceCube wireless pressure sensor can be measured in the following ways

1. Run 'Science#' and connect the sensor wirelessly or wired.
2. Connect the pressure sensor to the experimental device to be measured.
3. In [Sensor Settings], select the sensor range and unit you want to use.
4. If measurement is required starting from '0', execute [Zero Setting].
5. Set the [Data Collection Interval] and [Experiment Time] in [Experiment Settings].
6. Click [Start] to start the experiment.

For more information on how to use the Science# application, see the help.

Note : Pressure values displayed on the sensor are in kPa, and pressure values displayed in the Science# program are in hPa.

$$1 \text{ kPa} = 10 \text{ hPa}$$

Calibration

All sensors are shipped after being precisely calibrated using standard equipment during the manufacturing process, so they can be used right away and do not require a separate calibration process.

However, if you want to display "0" in the current value for a smooth experiment, proceed with **[Zero Point Setting]**. Zero point setting can be done separately in the wireless sensor or program.

[Sensor zero point setting]

1. Press the sensor's Power/Calibrate button twice in succession.
2. **[Zero point setting]** is completed, and the word "U0" is displayed above the unit on the sensor screen.
3. To cancel, press twice again and U0 will disappear and return to the default value.

Note : **[Zero point setting]** is reflected temporarily and returns to the default value when the sensor is turned on again.

[Zero setting] in science#

Science#'s zero setting does not affect the sensor's zero setting and is only reflected in the values displayed in the program.

If you press the  icon in the space where the sensor value is displayed in Science #, the **[Zero point setting]** menu will appear.

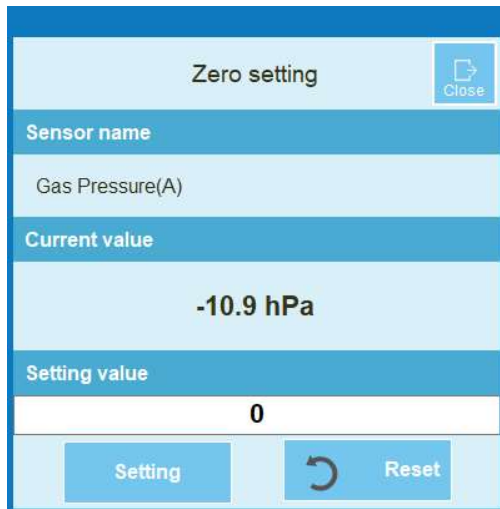

Here, if you press **[Setting]**, it will change to 0.0 hPa, and if you press **[Reset]**, it will return to the initial value.



Guide for scientific experiments

Boyle's law

Experiment Method



- ① Place the syringe on a 20 mL scale.
- ② Install the wireless gas pressure sensor A in the syringe.
- ③ Launch Science# and connect the wireless gas pressure sensor A.
- ① Press  to set zero point.
- ② Set[settings] to [Sampling Methods - Event-based] – [graph setting-Line/scatter]- [Touch Event-Number Title of X-axis: number]
- ③ Press  [start] to collect data

④ Place the syringe on the 20mL scale and press  [collect] to enter the syringe volume value '20' in the number input field.

⑧ Measure the pressure by decreasing the volume 1mL like the above method and input the volume by the same method up to 6mL.



Specifications

Item	Description
Range	-1,000 ~ +3,000 hPa (-100 ~ 300 kPa)
Resolution	0.6 hPa
Sampling Time	Max. 100Hz (0.01 sec.)
Condition	-20 ~ 60°C, 85%RH
Wireless Connection	Bluetooth 5.0 or Classic 2.1
Wired Connection	USB-C
Battery	700mAh Li-Polymer rechargeable
Charging Time	within 2 hours
Operating Time	Approximately 13 hours after full charge (depending on usage conditions)
EMC	CE : EN 61326-1, EN 55011, EN 55032, EN 301   202-SMD070

CAUTION: Do not use the instrument beyond the measurement range or in conditions that exceed the short-term exposure limits. Prolonged exposure beyond the maximum permissible range can cause serious damage to the sensor.

Rev. WL103P-02-2024

- The contents of this manual are provided for informational purposes only, and product specifications and functions may be changed without prior notice to improve performance.
- This product is designed for science education. No warranty is provided and no liability is assumed for errors in industrial testing or manufacturing process controls, medical analysis or controls, or commercial design applications.

TEL : +82-2-2109-8839 FAX : +82-2-2109-8881

www.sciencecube.com

Korea Digital Co., Ltd.

#804 Ace Twin Tower 273 Digital-ro Guro-gu Seoul 08381 Korea